



# LANDY MANUFACTURING

## OPERATOR MANUAL

**Skid Steer Snow Blower**

**MODEL: S-HSB1830(72IN)-MP1220**



[www.landymfg.com](http://www.landymfg.com)

[sales@landymfg.com](mailto:sales@landymfg.com)

## General

For us, the long lifecycle and efficiency of your new equipment is a priority. To keep the snow blower in top working condition, read this manual carefully before using the equipment.

Never let anyone operate or maintain the device without reading this manual carefully! Always make sure that safety precautions are observed in use and maintenance. Keep this manual for future reference and make sure to hand it over to a new owner.

The cornerstones of the product development of LANDY attachments are quality, durability and economy. The products are engineered to be high-performing, safe and durable in professional use. Any feedback on our products is welcome and contributes to the further development of our products.

**PLEASE ATTENTION:** Products Exchange or Refunds is not acceptable. If you have any questions about the use or maintenance of the Snow Blower, please contact us by e-mail: [sales@landymfg.com](mailto:sales@landymfg.com)

The manufacturer reserves the right for structural and technical changes without prior notice. Therefore, some pieces of information given in the manual may have changed after printing this manual.

### Read before use

Make sure you know your equipment before you start using it.

Equipment may be operated only by an individual who is thoroughly familiar with its use.

All operators must be properly instructed before use and maintenance of the equipment. Use by individuals with insufficient instructions may pose serious risks to the operators themselves, to the environment and the equipment.

When coupling the attachment to the base machine, make sure:

- that all locking cotters are intact and in order
- there is no pressure in the hydraulic system
- that hydraulic hoses are intact
- there is no skin contact to hydraulic oil when connecting hydraulic hoses
- not to pull by the hydraulic hoses, but only by the hydraulic fitting

During operation, pay attention to:

- safe, appropriate travel speed
- other traffic, people and animals
- danger zones and objects that block your view
- children

NEVER use the machine, if there is someone in the danger zone.

NEVER go under the attachment.

Check all bolts, nuts and hydraulic fittings for tightness after the first day of operation!

If the equipment is not likely to be used for a longer period of time, clean it thoroughly after use and lubricate as instructed.

## Table of contents

1. PURPOSE OF USE .....	3
2. SAFETY PRECAUTIONS .....	3-5
3. SAFETY SIGNS (DECALS).....	6
4. PARTS OF THE DOZER BLADE.....	7-16
5. OPERATION - HYDRAULIC SERIES .....	17
6. MAINTENANCE.....	18-19

## 1. PURPOSE OF USE

For snow moving in winter.

## 2. SAFETY PRECAUTIONS

Make sure you know your equipment before you start using it. Equipment may be operated only by an individual who is thoroughly familiar with its use.

Before connecting hydraulics to the base machine, make sure that:

- there is no-one between the attachment and the base machine
- the base machine is turned off and the parking brake is on.

When coupling the attachment to the base machine, make sure that:

- all locking cotters are intact and in order
- hydraulic hoses are intact
- there is no skin contact to hydraulic oil when connecting hydraulic hoses
- you do not pull by the hydraulic hoses, but only by the hydraulic fitting.

During operation, pay attention to:

- safe, appropriate travel speed
- other traffic, people and animals
- danger zones and objects that block your view
- children
- use of turn signal when driving

NEVER use the machine, if there is someone in the danger zone

NEVER go under the attachment

During maintenance, the hydraulics of the base machine MUST be turned off. The base machine MUST also be turned off and the parking brake MUST be applied. The equipment must be properly supported, if maintenance can only be performed by going under the equipment. Never go under the equipment if it is not properly supported.

Daily maintenance:

- check general condition of structures, make repairs if needed
- check the hydraulic hoses and fittings, and replace damaged parts

After every 50 hours of operation:

- lubricate points specified in later section of this manual
- check all bolts and nuts for tightness

**WARNING!** Pressurized hydraulic hoses and components!

### 2.1 Transport Safety

- Do not exceed 20 mph (32 kph). Reduce speed on rough roads and surfaces.

- Comply with state and local laws governing highway safety and movement of machinery on public roads.
- The use of flashing amber lights is acceptable in most localities. However, some localities prohibit their use.
- Local laws should be checked for all highway lighting and marking requirements.
- Always yield to oncoming traffic in all situations and move to the side of the road so any following traffic may pass.
- Always enter curves or drive up or down hills at a low speed and at a gradual steering angle.
- Never allow riders on either tractor or equipment.
- Keep tractor / towing vehicle in a lower gear at all times when traveling down steep grades.
- Maintain proper brake settings at all times (if equipped).

## **2.2 Skid Steer Safety**

- Read and understand the operator' s manual before using the skid steer. Follow the manufacturer' s recommendations and specifications when operating.
- Always lower the bucket or attachment so that it is flat on the ground.
- Do not leave the operator' s position while the engine is on.
- Keep all body parts inside the cab while operating a skid-steer loader.
- Never modify, bypass, disable, or override safety systems.
- Never operate equipment in which safety systems have been modified or are not working properly.
- Equipment with modified or malfunctioning safety systems should be taken out of service until repaired or replaced.
- Never permit riders on the skid-steer attachment, or in the operator' s compartment unless the compartment is designed to accommodate a second rider.
- Keep bystanders a safe distance away from the work area.
- Never attempt maintenance or other work while lift arms or attachments are raised without using an approved lift arm support device. Replace protective guards and shields after repairs or service.
- Train personnel on the proper inspection, use, maintenance, and repair of skid-steer loaders according to the manufacturer' s instructions.
- Train personnel to identify hazards, such as safety systems that have been bypassed, disabled, or that require maintenance.

## **2.3 Maintenance**

- The machine and some equipment have components that are at high temperatures under normal operating conditions. The primary source of high temperatures is the engine and exhaust system. The electrical system, if damaged or incorrectly maintained, can be a source of arcs or sparks.
- Flammable debris (leaves, straw, etc.) must be removed regularly. If flammable debris is allowed to accumulate, it can cause a fire hazard. Clean often to avoid this accumulation. Flammable debris in the engine compartment is a potential fire hazard. The operator' s area, engine compartment and engine cooling system must be inspected every day and cleaned if necessary to prevent fire hazards and overheating.
- All fuels, most lubricants and some coolant mixtures are flammable. Flammable fluids that are leaking or spilled onto hot surfaces or onto electrical components can cause a fire.

## **2.4 Operation**

- The Farm King machine must be in good operating condition before use.
- Check all of the items listed on the service schedule under the 8 hour column before operation. (See Maintenance section)
- Do not use the machine where exhaust, arcs, sparks or hot components can contact flammable material,

explosive dust or gases.

## **2.5 Starting**

- Do not use ether or starting fluids on any engine that has glow plugs. These starting aids can cause explosion and injure you or bystanders.
- Use the procedure in the tractor's operator's manual for connecting the battery and for jump starting

## **2.6 Electrical**

- Check all electrical wiring and connections for damage. Keep the battery terminals clean and tight. Repair or replace any damaged part or wires that are loose or frayed.
- Battery gas can explode and cause serious injury. Do not jump start or charge a frozen or damaged battery. Keep any open flames or sparks away from batteries. Do not smoke in battery charging area.

## **2.7 Hydraulic System**

- Check hydraulic tubes, hoses and fittings for damage and leakage. Never use open flame or bare skin to check for leaks. Hydraulic tubes and hoses must be properly routed and have adequate support and secure clamps. Tighten or replace any parts that show leakage.
- Always clean fluid spills. Do not use gasoline or diesel fuel for cleaning parts. Use commercial nonflammable solvents.

## **2.8 Fueling**

- Stop the engine and let it cool before adding fuel. No smoking! Do not refuel a machine near open flames or sparks. Fill the fuel tank outdoors.

## **2.9 Fire Extinguishers**

Know where fire extinguishers and first aid kits are located and how to use them. Inspect the fire extinguisher and service the fire extinguisher regularly. Obey the recommendations on the instructions plate.

### 3. SAFETY SIGNS (DECALS)

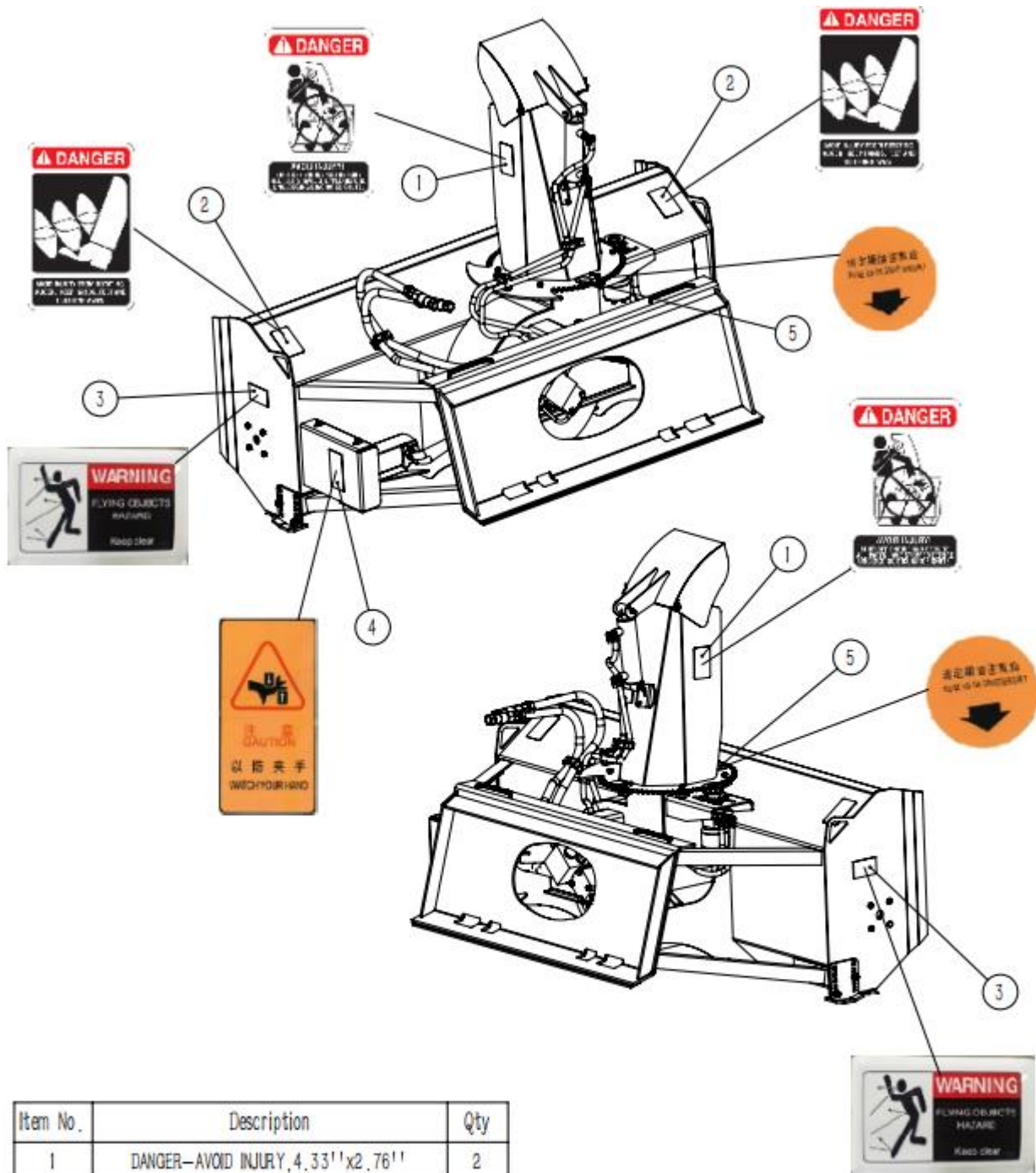

Item No.	Description	Qty
1	DANGER-AVOID INJURY, 4.33'x2.76''	2
2	DANGER, 4.53'x2.95''	2
3	WARNING-FLYING OBJECTS HAZARD, 3.94'x2.36''	2
4	TO PREVENT PINCHING, 5.52'x2.76''	1
5	PLEASE ADD BUTTER REGULARLY	2

## 4. PARTS OF THE DOZER BLADE

Snow Blower Frame and Fan Drive

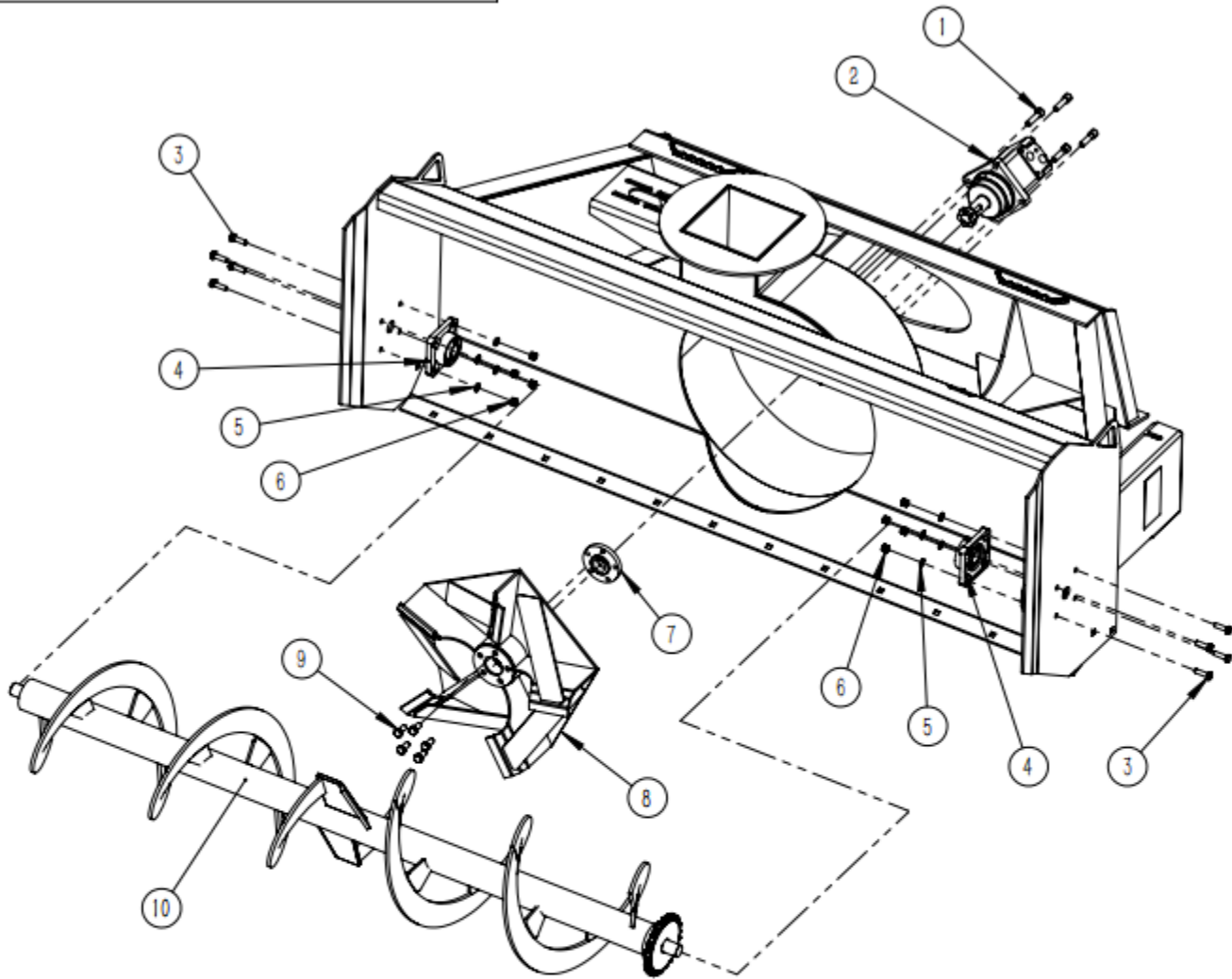

Item No.	Description	Qty
1	BOLT, 1/2''x1-3/4''GRADE 5	4
2	BLOWER MOTOR&VALVE	1
3	BOLT, CARRIAGE 3/8''x1-2/5''GRADE 5	8
4	BEARING, 1-1/5''	2
5	WASHER, 3/8''	8
6	NUT, 3/8''	8
7	WHEEL, HUB 5 BOLT 1-1/4''	1
8	FAN, BLOWER 20'' CONTOURED	1
9	BOLT, 1/2''x1''GRADE 5	5
10	AUGER, 72'' BLW 13''W/SPROCKET	1



Auger with Sprocket, 72'' x 13''

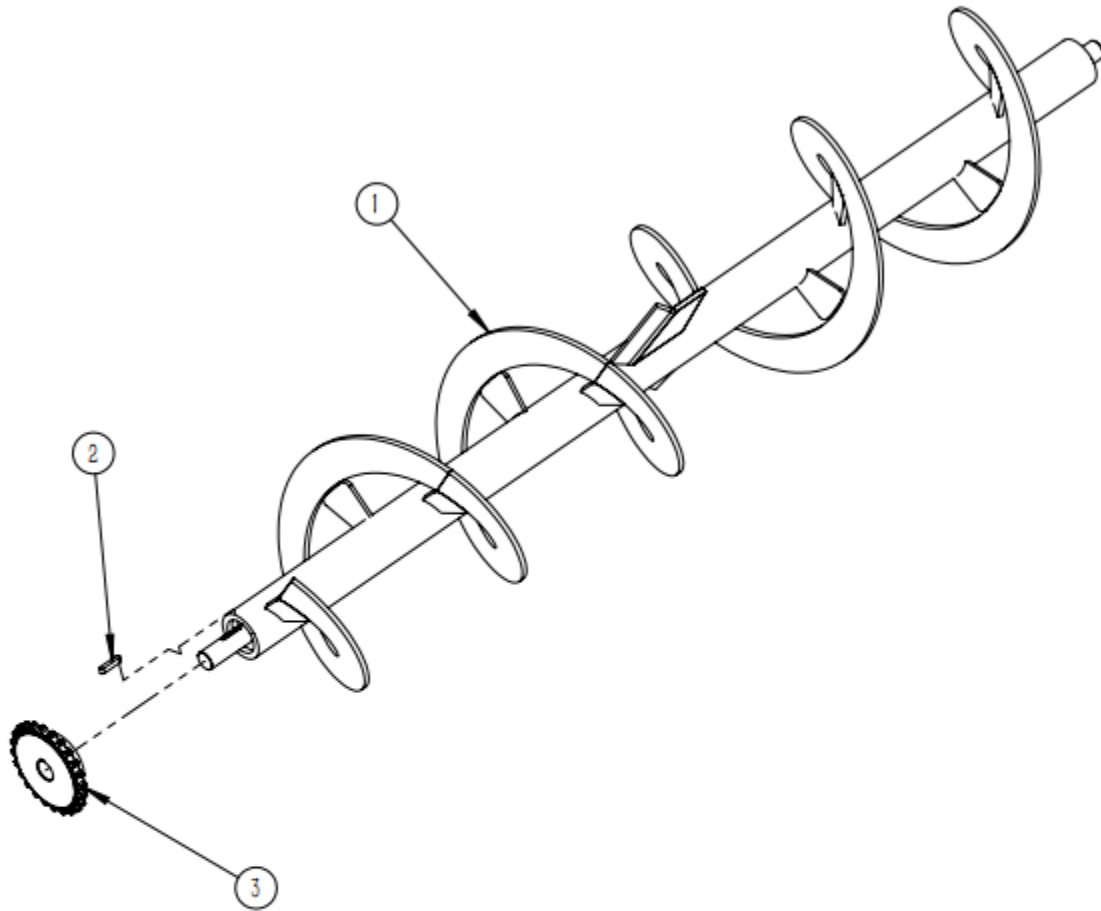

Item No.	Description	Qty
1	AUGER, 72'' BLOWER 13''	1
2	KEY, 1/3'' x 1-3/5''	1
3	SPROCKET, 12A24 1-1/4''	1

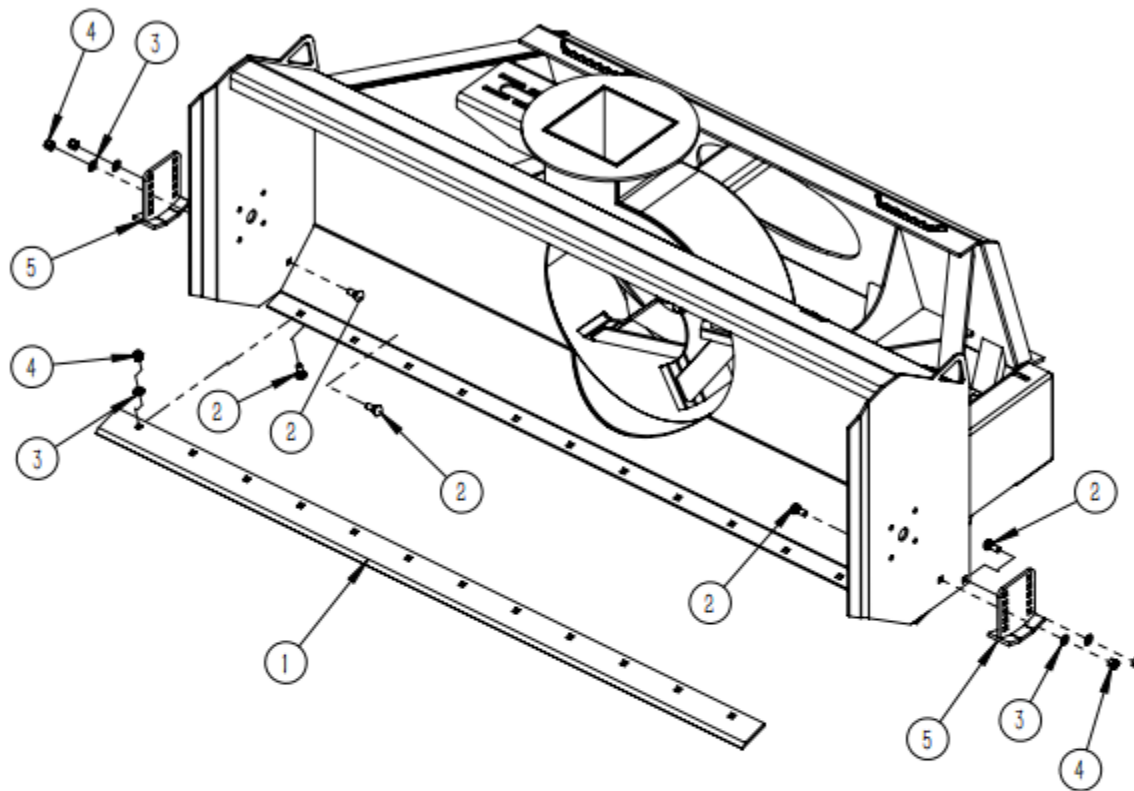

Item No.	Description	Qty
1	EDGE, 72" BOLT-ON CUTTING	1
2	BOLT, CARRIAGE 1/2"x1-1/4"	16
3	WASHER, 1/2" SAE FLAT	16
4	NUT, LOCK 1/2" TOP	16
5	SHOE, SNBLW SIDE SKID	2

Spout with Deflector, 9.5''

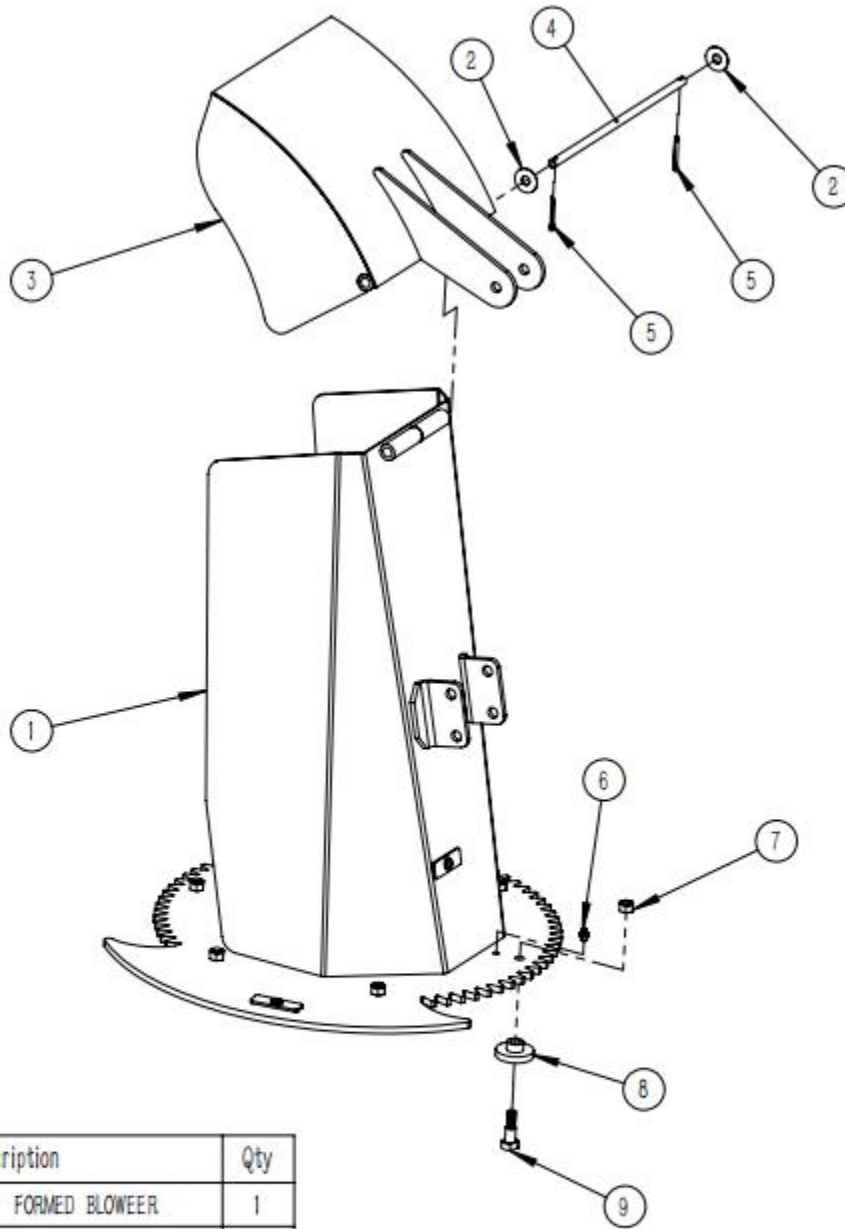

Item No.	Description	Qty
1	SPOUT, 9-1/2'' FORMED BLOWEER	1
2	WASHER, 3/8'' ID x 1/2'' WALL x 1-1/5'' OD	2
3	DEFLECTOR, 9-1/2'' SPOUT	1
4	ROD, 9-1/2'' SPOUT DEFLECTOR	1
5	COTTER PN, 3/19'' x 1-1/4''	2
6	GREASEZERK, DRIVE-IN	2
7	NUT, LOCK 3/8''	6
8	WASHER, STEP 1/2'' ID	6
9	BOLT, SHLD. 1/2'' x 1/2''	6

# Auger Drive

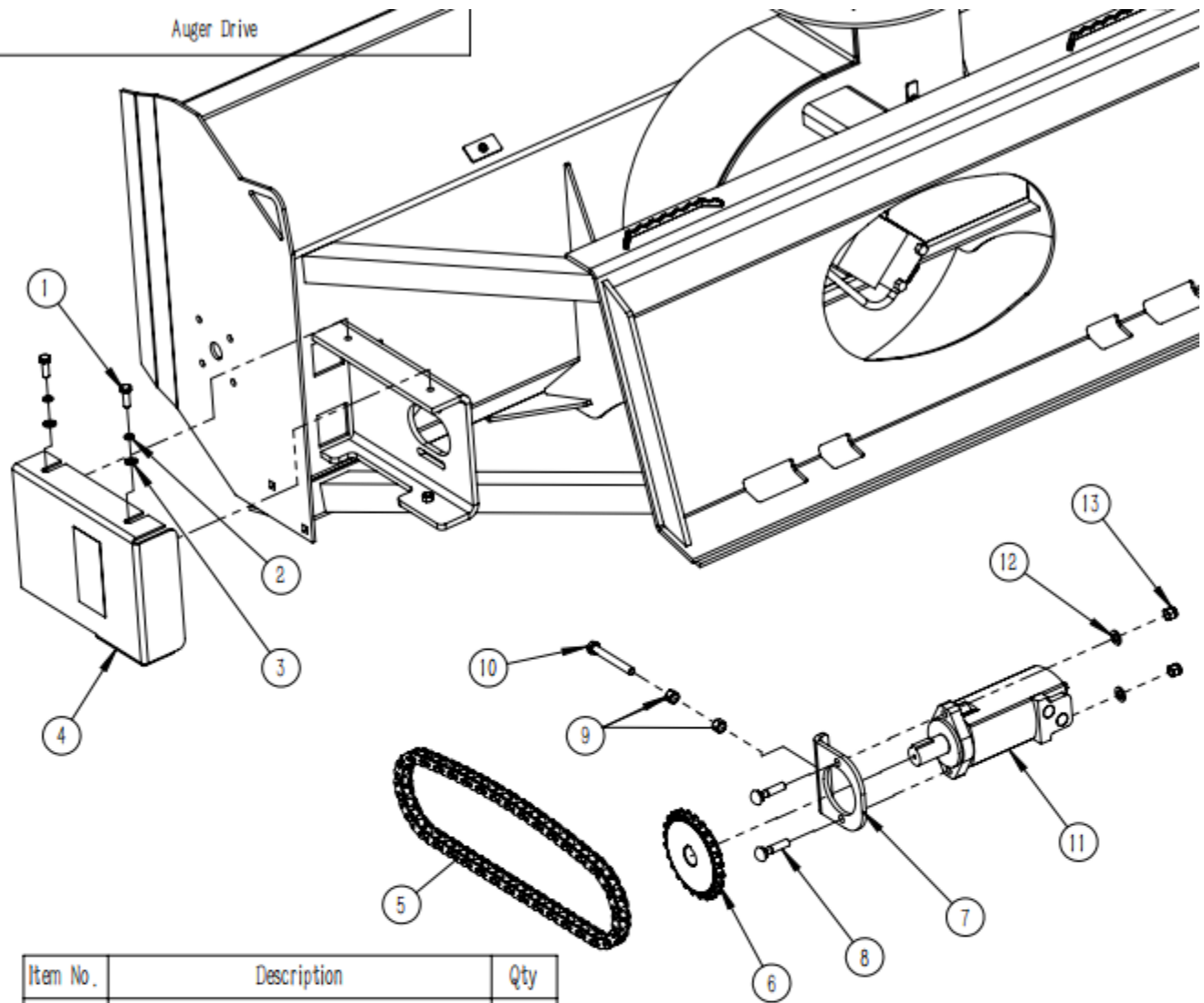

Item No.	Description	Qty
1	BOLT, 3/8" x 1-1/5" GRADE 5	3
2	WASHER, 3/8" LOCK	3
3	WASHER, FLAT 3/8"	3
4	COVER, SNBLW CHAIN	1
5	CHAIN, 12A x 19.05 PITCH	1
6	SPROCKET, 12A 19.05 1-1/4" BORE	1
7	PLATE, SNBLW MOTOR ADJ	1
8	BOLT, CARRIAGE 1/2" x 2-1/5"	2
9	NUT, LOCK 1/2" SERRATED FLANGE	2
10	BOLT, 1/2" x 3-3/4" GRADE 5	1
11	MOTOR, 18.7 CID SIDE PORT	1
12	WASHER, 1/2" NORDLOCK	2
13	NUT, STANDARD 1/2"	2

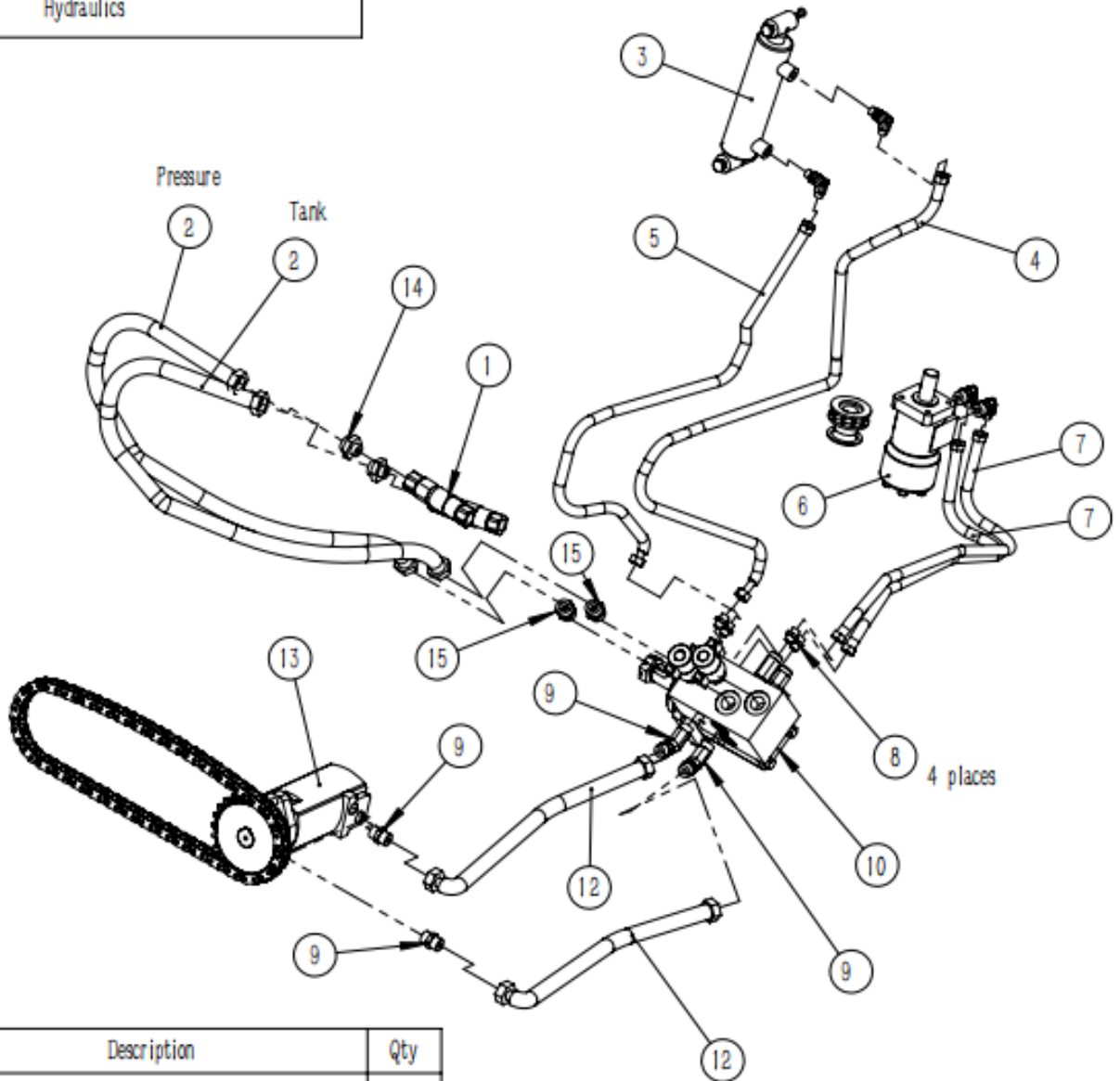

Item No.	Description	Qty
1	NPT1-2 QUICK CHANGE CONNECTOR	2
2	HOSE 5/8x100-1-1/16 SWFJICx1-1/16 SWFJIC	2
3	KIT, SPOUT HYD DEFLECTOR	1
4	HOSE 3/8x75-9/16 SWFJICx9/16 SWFJIC90	1
5	HOSE 3/8x65-9/16 SWFJICx9/16 SWFJIC90	1
6	ROTATOR, HYDRAULIC SPOUT KIT	1
7	HOSE 3/8x32.5-9/16 SWFJICx7/10 SWFJIC	2
8	ADAPTER, 9/16 MJIC-9/16 MOR	4
9	ADAPTER 7/8M O-RING TO 1-1/16" JIC	4
10	ASM, BLOWER MOTOR & VALVE	1

12	HOSE 5/8x29-1-1/16SWFJIC90x1-1/16SWFJIC□5	2
13	MOTOR, 18.7 CID SIDE PORT	1
14	1-1/16" 1-2NPT TRANSITION JOINT	2
15	1-1/16" 1-1/16" PIPE JOINT	2

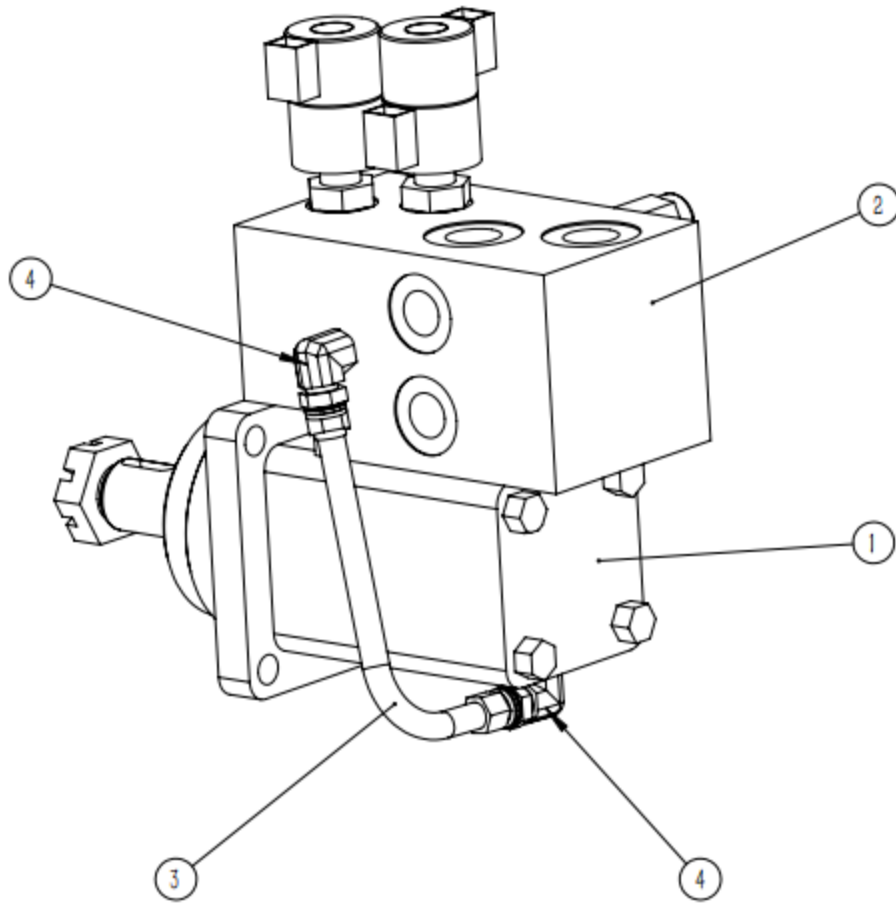

Item No.	Description	Qty
1	MOTOR, 6.2 CID 17-23 GPM	1
2	VALVE, SNBLW ACTUATORS	1
3	TUBE, SNBLW-4FJIC-4FJIC	1
4	ELBOW, 90 EDG-4MJIC-4MORB	2

Actuator Valve

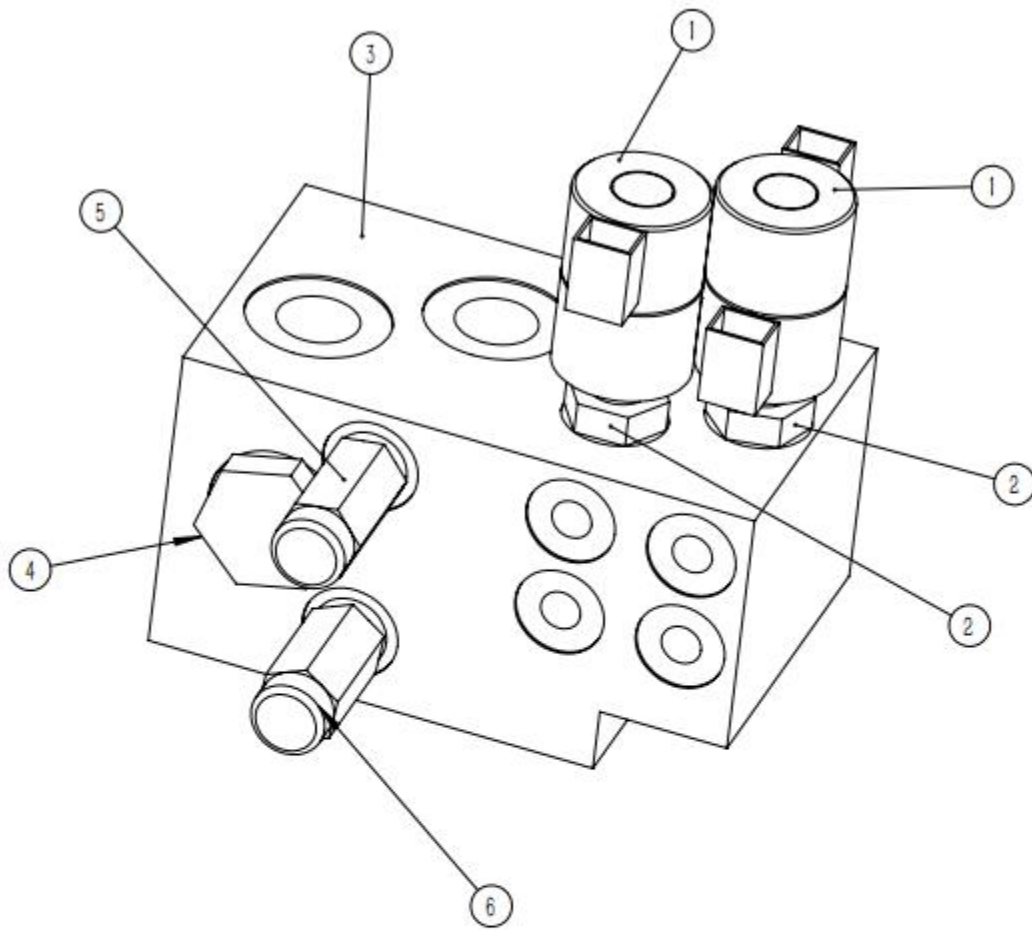

Item No.	Description	Qty
1	COIL, DEUTSCH 12V #8	4
2	SPOOL, TANDEM CENTER #8 4W3P	2
3	BLOCK, 2K CONTROL	1
4	SPOOL, PILOT #16 10PSI	1
5	POPPET, RELIEF #8 1000 PSI	1
6	SPOOL, RELIEF PO #10 1600 PSI	1

Spout Hydraulic Deflector Kit

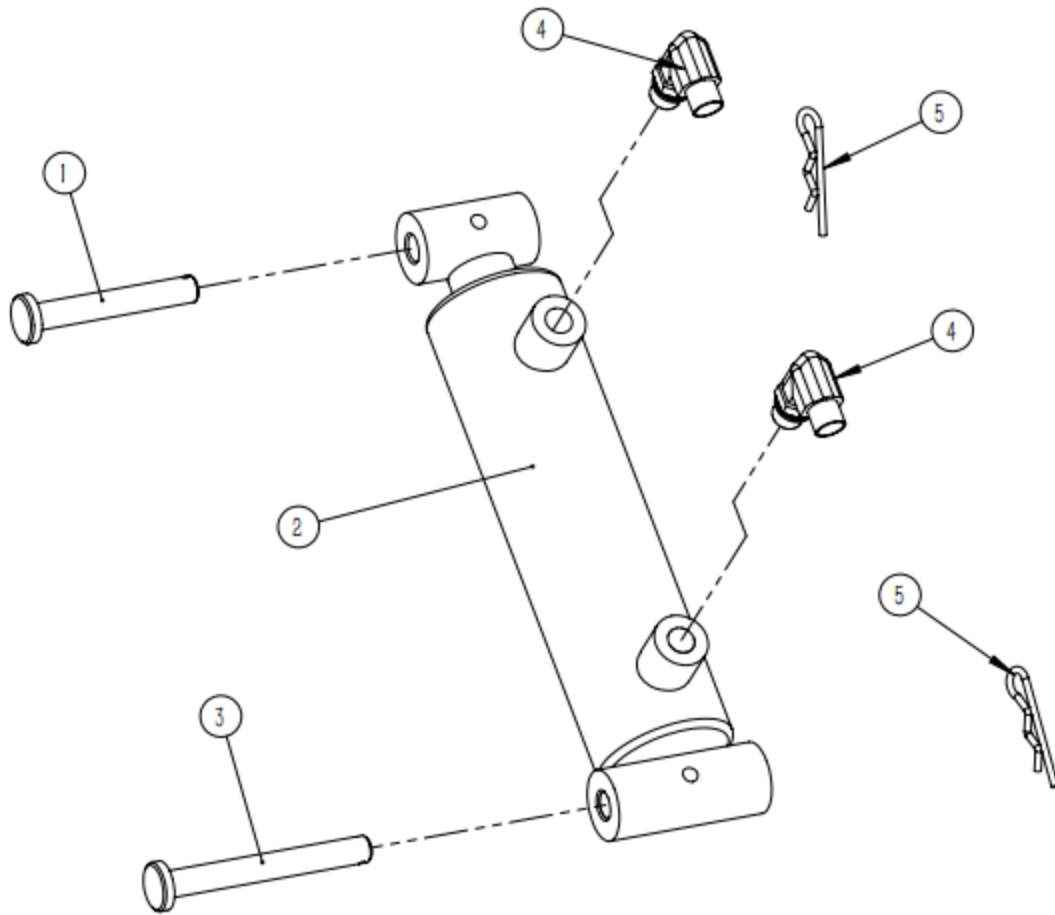

Item No.	Description	Qty
1	PIN, DEFLECTOR 1/2''x3.15'' TOP	1
2	CYLINDER, HYDRAULIC 2''x5.2''	1
3	PIN, DEFLECTOR 1/2''x4'' BTM	1
4	ELBOW, 90EDG-9/16 MORBx9/16 MJIC	2
5	CLIP, HARPN 0.093x1-5/8''	2



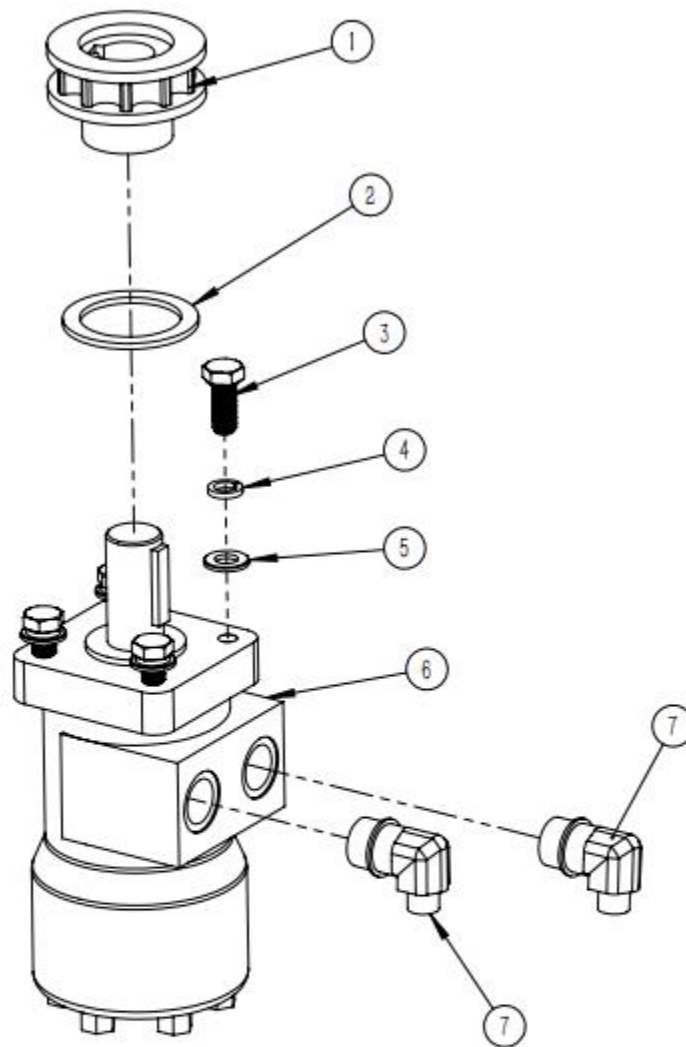

Item No.	Description	Qty
1	SPROCKET, SPOUT ROTATOR	1
2	WASHER, 2.36" OD x 1.77" ID x 0.11	1
3	BOLT, 3/8" x 1" GRADE 5	4
4	WASHER, 3/8 LOCK	4
5	WASHER, FLAT 3/8"	4
6	MOTOR	1
7	ELBOW, 90 DEG - 7/8 MORB x 7/10 M/JC	2

Units:mm

Product size:

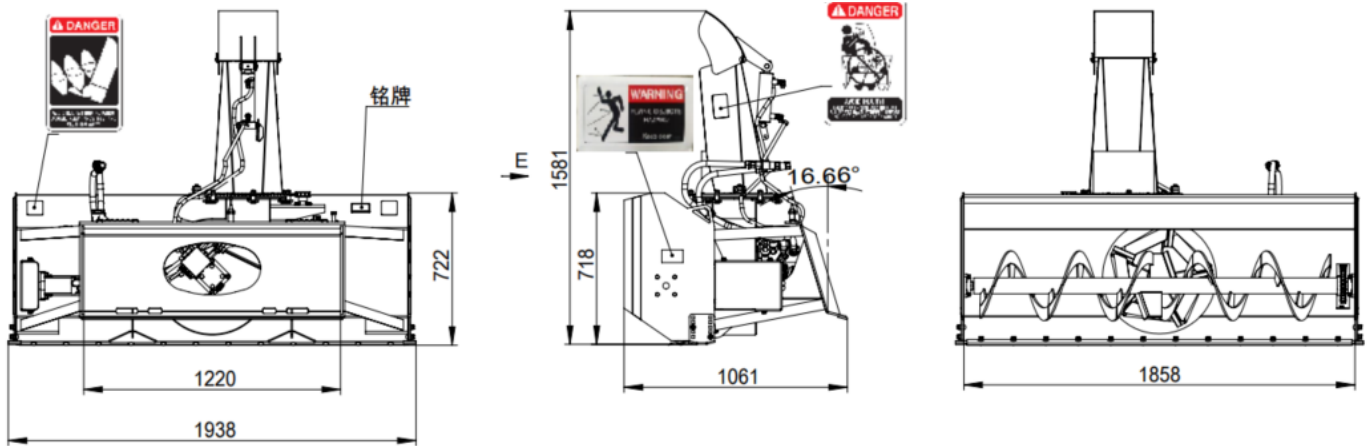

Mount on plate:

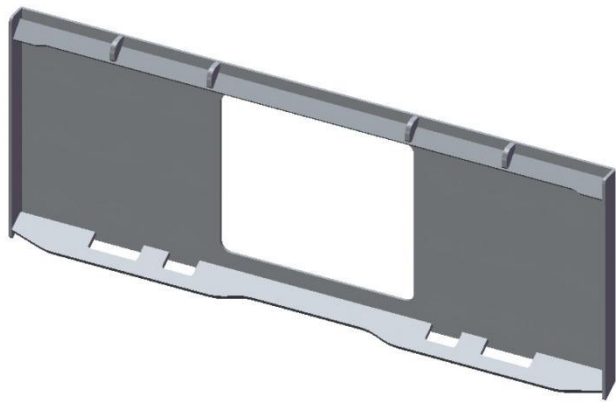
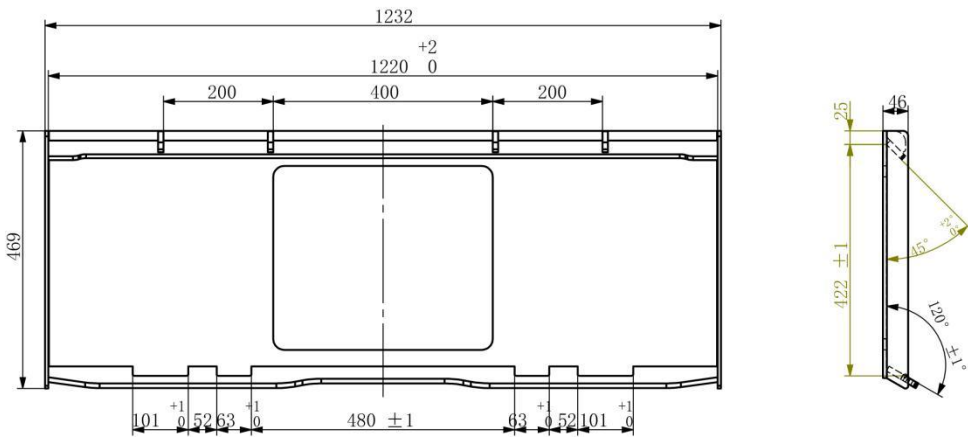

## 5. OPERATION - HYDRAULIC SERIES

### 5.1 Pre - Operation Checklist

Before operating the snowblower for the first time and each time thereafter, check the following items:

1. Lubricate the equipment per the schedule outline in the Maintenance Section.
2. Check the snowblower hitch for damaged, loose or missing parts. Repair as needed before operation.  
Note: Do not operate with leaks.
3. Make sure that all guards and shields are in place, secured and functioning as designed.
4. Check condition of all hydraulic components for leaks. Repair as required.
5. Check that all electrical connections are tight.
6. Check the augers. Remove any twine, wire or other material that has become entangled.

## **5.2 Connecting The Snowblower To Skid Steer**

1. The implement should be blocked and positioned on a flat level surface.
2. Enter the tractor operator's position
3. Start the engine.
4. Move the tractor into position behind the implement skid steer mount plate.
5. Stop the engine and leave the operator's position
6. Proceed with connecting the tractor and implement skid steer mounts.

### **IMPORTANT**

See tractor operator's manual for proper connection to the implement.

## **5.3 Connecting Hydraulic Hoses**

The snowblower is equipped with the following hydraulic functions:

1. Hydraulic motor auger drive
2. Hydraulic motor fan drive
3. Hydraulic motor spout rotation
4. Hydraulic cylinder spout deflector

Push couplers into female couplers on the tractor until they are fully engaged and locked.

### **IMPORTANT**

Contain and dispose of any oil leakage in an environmentally safe manner.

Thoroughly clean the quick couplers before making connections. Dirt can quickly damage the system.

## **5.4 Transporting**

Always comply with federal, state, local and provincial laws regarding the transport of farm equipment on public roadways.

### **IMPORTANT**

Never exceed 20 mph (32 kph)

### **WARNING**

1. Verify that the tractor / tow vehicle is approved for transporting the equipment and that the equipment is securely attached to the tractor / tow vehicle.
2. Verify safety chain is installed and properly connected before transporting equipment.
3. Verify that the SMV (Slow Moving Vehicle) emblem, all lights and reflectors are clean and visible.
4. The ratio of the tractor / tow vehicle weight to the loaded equipment weight plays an important role in defining acceptable travel speed.

5. TRAVEL SPEED - Acceptable travel speed.

6. WEIGHT RATIO - Weight of fully equipped or loaded implement(s) relative to weight of tractor / tow vehicle.

Travel Speed	Weight Ratio
20 mph (32 kph)	Less than 1 to 1
10 mph (16 kph)	Less than 2 to 1
DO NOT TOW	More than 2 to 1

## 6. MAINTENANCE

### 6.1 General safety precautions for the use and maintenance

- Comply with existing laws and regulations and the instructions given in this manual.
- Never go under an unsecured device.
- Always apply the parking brake of the base machine before performing any actions on the device.
- Only use tools that are in proper working order.
- Be careful with the pressurized hydraulic hoses and components.
- Make sure there is no pressure in the hydraulic system. Take into account the pressure accumulator.
- Make sure hydraulic fluids or greases do not leak to the ground.
- Use all necessary personal protectors.

### 6.2. Daily maintenance

In order to prevent further damages, it is important to inspect the device visually for possible defects. Inspect at least the following daily:

- hydraulic hoses and components for possible leaks
- general mechanical functioning

### 6.3. Maintenance after first 10 hours of operation

- Lubricate, preferably with a grease or equivalent.
- Check all bolts and nuts for tightness.

### 6.4. Maintenance at 50-working hour intervals or on a weekly basis

- Lubricate, preferably with a grease or equivalent.
- Check the mechanical condition of the device for bends, distortions or breaches
- Check fastening bolts for tightness.

## 6.5 Troubleshooting

ISSUE	PROBABLE CAUSE	REMEDY
Nothing works	<ul style="list-style-type: none"><li>• Hydraulic valve not engaged</li><li>• One or more quick couplers not completely engaged</li></ul>	<ul style="list-style-type: none"><li>• Engage to full detent</li><li>• Fully engage all couplers</li><li>• Switch flow direction using controls or swapping hose</li></ul>

<p>Chute controls operate backwards</p>	<ul style="list-style-type: none"> <li>• Control box mounted in wrong orientation</li> <li>• Wiring connected improperly on valve manifold</li> </ul>	<ul style="list-style-type: none"> <li>• Mount in appropriate orientation</li> <li>• If not possible, connections may be swapped underneath manifold cover</li> </ul>
<p>One control switch operates two different chute functions</p>	<ul style="list-style-type: none"> <li>• Wires connected improperly on valve manifold</li> </ul>	<ul style="list-style-type: none"> <li>• Connect wires in proper arrangement</li> </ul>