



LANDY MANUFACTURING

OPERATOR MANUAL

FORKLIFT TILT JIB LONG

MODEL: F-TJCL45

RB: TJCL45



www.landymfg.com

sales@landymfg.com

1) GENERAL DESCRIPTION of PRODUCT

The type TJCL45 Tilt Jib (Long) is one of our most versatile Forklift Jib attachments in our range, allowing extra height to 2.23 metres, with a 3.53 metre reach when fully extended. This slip-on attachment is held to the Forklift by a safety chain. The Jibs overall length when closed is 2.1 metres.

A locking safety chain is supplied to prevent the Jib from moving off the fork arms. They are paint finish safety yellow.

The TJCL45 jibs can lift loads in accordance with the Load Capacity Tables provided in Pic.1.

PLEASE ATTENTION: Products Exchange or Refunds is not acceptable. If you have any questions about the use or maintenance of TJCL45 Jib, please contact us by e-mail: sales@landymfg.com



WARNING: These Instructions **MUST** be READ in FULL by the Operator and all Operational & Safety Procedures and Risk Control Measures complied with before the use of this attachment.

2) METHOD of ATTACHMENT to FORKS

Before installation of the attachment onto a forklift, ensure that the fork arms are suited and set to the correct width.

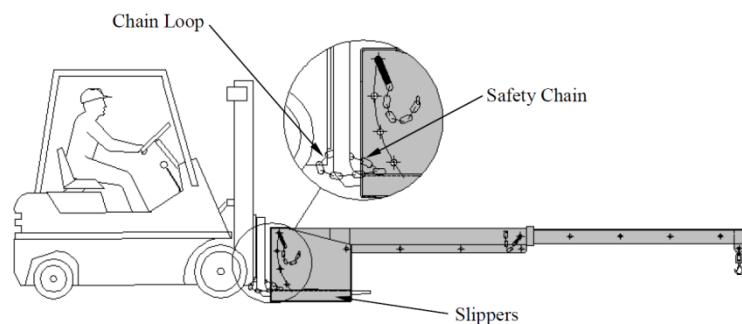

Pic. 1

To install the attachment, engage the forklift arm into the slippers as shown in Pic.1. With the fork arm shank (vertical face) firmly against the rear of the attachment, run the rear safety chain provided around the carriage or tower. Re-attach the chain to itself by using the snap hook provided.

3) OPERATIONAL and SAFETY PROCEDURES

Preliminary Safety Checks

A "Competent Person" shall check the following;

- (1) that all locating pins are correctly positioned and are in safe working order and safety clipped,
- (2) that the Jib hook assembly is correctly fitted and in safe working order,
- (3) that the safety chains are in good condition,
- (4) that the shackle securing the swivel hook is correctly installed and tightened.

The Operator shall check that the attachment has been correctly fitted in accordance with these Instructions (refer Section 2), and/or the relevant Industrial Truck Operator's Manual. The Operator shall consult the load tables provided and ensure that the industrial truck or attachment lift capacity is not exceeded. Refer Pic.1.

General Operating and Safety Procedures

To extend the Jib remove the safety clip and withdraw the front locking pin, select the preferred extension, then reinsert the locking pin through the Outer and Inner Jib sections. Reinsert the safety clip.

Handling suspended loads by an attachment can introduce dynamic loads affecting stability. Sudden stops, starts and turns can cause the load to swing and create a hazard.

Forklift attachments can alter load centres and reduce the load capacity. The type of load to be handled in addition to the operating conditions must be considered when determining the actual working capacity for each application. Do not exceed the recommended forklift or attachment rating.

When lifting with a Jib attachment the net lifting capacity should be 0.8 times the rating of the truck.



WARNING: Any SWL noted on the attachment is a structural rating of the attachment only and makes no claim to the suitability of the forklift. Actual load may be restricted to the suitability of the forklift. Actual lift truck capacities must be obtained from the lift truck manufacturer.

JIB attachments shall not be modified in any way which affects the operation or performance except with the prior approval of MANUFACTURE. After any changes have been effected, appropriate alterations shall be made on the relevant nameplate and markings prior to placing the attachment back into service. MANUFACTURE must be notified of the changes to name plates and makings with reference to the attachment serial number.

4) RISK CONTROL MEASURES – SUMMARY

When handling loads, the following Risk Control Measures are to be observed by the operator to ensure all identified hazards relative to using this equipment are eliminated or controlled – refer Appendix A for a detailed analysis;

A) The Industrial Truck Operator requires a suitable forklift licence to cover both the Industrial Truck being operated and the attachment that has been fitted. Training in the safe use of the attachment and the use of lifting booms, slings and chains for lifting shall be undertaken before usage.

B) Authorised personnel must perform the following pre-checks immediately prior to the use of the Industrial Truck and corrective action initiated where applicable;

- * Nameplate and markings regarding the Industrial Truck and Attachment capacities are to be read and acknowledged,
- * Condition of lift and tilt systems on the Industrial Truck to be checked,
- * Inspect all tyres for wear, condition and pressure if applicable,

* Liquid levels of battery cell electrolyte, oils (hydraulic, engine, transmission and brake), cooling water and fuel to be checked,

* All steering and brake controls, warning devices and lights to be checked for effective operation.

C) Gain assurance from a responsible person that the load may be handled safely with an attachment and that person has provided all information necessary to ensure that risks are eliminated or controlled.

D) Do not exceed the rated capacity of the Industrial Truck to handle the load.

E) The Industrial Trucks shall be used on a hard level surface. The area in which the attachment is to be used has been assessed as suitable for the task to be undertaken.

There should be suitable clear space to safely use the attachment and a system developed for handling the load.

F) While lifting in an area subject to passing traffic, barriers or warning signs shall be used to prevent any interference.

G) Manoeuvre slowly and cautiously when the load is elevated.

H) Transport the load with the attachment positioned as low as practicable.

I) The mast, if adjustable shall be set at vertical or back tilted.

J) Never drag the load horizontally along the ground.

K) The Operator shall check the attachment is securely attached, refer Pic.1.

L) The Operator shall stay with the Industrial Truck controls at all times.

M) The Operator shall keep hands and feet clear of controls other than controls in use.

N) The Operator shall keep clear of overhead obstructions and in particular

MAINTAIN RELEVANT CLEARANCE OF ELECTRICAL CONDUCTORS.

O) Before any load is hoisted by the attachment, the Operator shall lift the attachment unladen to the required working height to confirm that all systems are functioning correctly.

P) Ensure safety features are provided, visible and working effectively.

Q) Ensure there has been no unauthorised interference or alteration to the plant that may cause risk.

R) Ensure regular maintenance, testing and inspections are carried out and recorded in accordance with the relevant Industrial Truck Manuals and corrective action initiated where applicable.

S) Ensure the instructions of LANDY industries are followed.

T) If any of the equipment becomes unsafe, stop all usage until the risk is eliminated or controlled



WARNING: Failure to observe the above Risk Control Measures and those outlined in Appendix A could result in **SERIOUS INJURY** or **DEATH**.

5) LOAD CAPACITY TABLES

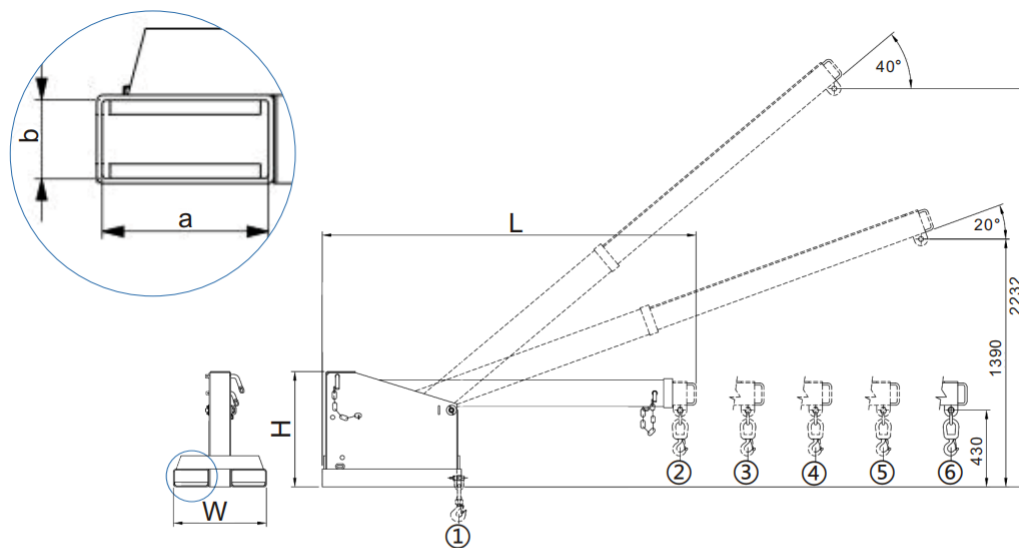

Type	Dimension(LWH)/mm	Pocket Size(ab)/mm	Weight/kg
F-TJCL45	2097×522×646	185×68	190

Position	1	2	3	4	5	6
Extension/mm	770	2010	2390	2770	3150	3530
SWL/kg	4500	1100	630	470	300	150

Pic. 2